

**Figure 7.** Frequency shifts in the vibrational spectrum of iodocynoacetylene induced by complex formation with triphenylphosphine oxide (with  $\text{Et}_2\text{S}$  for  $\nu(\text{C}-\text{C})$ ) in  $\text{CS}_2$  for  $\nu(\text{C}-\text{C})$ ). Cell thickness and concentrations:  $\nu(\text{C}\equiv\text{N})$  1.5 mm,  $\text{IC}\equiv\text{CCN}$  0.006 M,  $\text{Ph}_3\text{PO}$  (a) 0, (b) 0.011, (c) 0.036 M;  $\nu(\text{C}\equiv\text{C})$  6 mm,  $\text{IC}\equiv\text{CCN}$  0.012 M,  $\text{Ph}_3\text{PO}$  (a) 0, (b) 0.02, (c) 0.06 M;  $\nu(\text{C}-\text{C})$  1 mm,  $\text{IC}\equiv\text{CCN}$  0.11 M,  $\text{Et}_2\text{S}$  (a) 0, (b) 0.2, (c) 1 M;  $\delta(\text{CCN})$  0.5 mm,  $\text{IC}\equiv\text{CCN}$  0.15 M,  $\text{Ph}_3\text{PO}$  (a) 0, (b) 0.04, (c) 0.27 M;  $\nu(\text{C}-\text{I})$  1 mm,  $\text{IC}\equiv\text{CCN}$  0.4 M,  $\text{Ph}_3\text{PO}$  (a) 0, (b) 0.36 M; and  $\delta(\text{C}\equiv\text{C}-\text{C})$  1 mm,  $\text{IC}\equiv\text{CCN}$  0.13 M,  $\text{Ph}_3\text{PO}$  (a) 0, (b) 0.14 M.

Küppers).<sup>34</sup> In the second method, the 1-alkynes react with mercury acetate and iodine as described for iodotrimethylethynylsilane by Shostakovskii et al.<sup>35</sup> The second method can be carried out on a larger scale with better yields and was generally preferred. 1-Iodoacetylenes are purified by vacuum distillation on a spinning-band column for  $\text{IC}\equiv\text{CPr}$  (bp 53 °C (22 mm)),  $\text{IC}\equiv\text{CPh}$  (bp, 90–91 °C (2 mm)),  $\text{IC}\equiv\text{CCH}_2\text{Br}$  (bp 62–63 °C (3–5 mm)), and  $\text{IC}\equiv\text{CSiEt}_3$  (bp 60 °C (2 mm)) or by recrystallization in cyclohexane for  $\text{IC}\equiv\text{CC}_6\text{H}_4\text{NO}_2$  (mp 182 °C),  $\text{IC}\equiv\text{CCN}$  (mp 152 °C),  $\text{IC}\equiv\text{CCOOEt}$  (mp 74.5 °C) or in pentane for  $\text{IC}\equiv\text{CI}$  (mp 78 °C). When purified and if not immediately used they are protected from light and stored in the cold. Most of the starting 1-alkynes are commercial products with the exception of triethylethynylsilane prepared from  $\text{HC}\equiv\text{CMgBr}$  and  $\text{Et}_3\text{SiBr}$  as described by Shchukovskaya and Petrov,<sup>36</sup> cyanoacetylene prepared from propiolic

acid as described by Miller and Lemmon,<sup>37</sup> and *p*-nitrophenylacetylene prepared from *trans-p*-nitrocinnamic acid by the method of Cristol et al.<sup>38</sup>

**Infrared spectra** were recorded on a Beckman IR12 spectrophotometer with KBr cells in the 4000–400- $\text{cm}^{-1}$  region and CsI cells in the 250–400- $\text{cm}^{-1}$  region. Overlapping free and complex bands were mathematically separated using the program of Jones et al.<sup>39</sup>

Solutions were prepared and the cells were filled in a dry box. They were carefully protected from light. Reactions occur between 1-iodoacetylenes and some bases, for example, between *N*-methylaniline and  $\text{IC}\equiv\text{CCN}$  or  $\text{IC}\equiv\text{CPh}$  or between  $\text{Ph}_3\text{PSe}$  and  $\text{IC}\equiv\text{CPh}$ , but the reaction is slow enough so that spectra could be recorded. Some difficulties were also encountered with the complex solubility in apolar solvents.

(36) L. L. Shchukovskaya and A. D. Petrov, *Izv. Akad. Nauk SSSR, Otd. Khim. Nauk*, 1011 (1958).

(37) F. A. Miller and D. H. Lemmon, *Spectrochim. Acta, Part A*, **23**, 1415 (1967).

(38) S. J. Cristol, A. Begoon, W. P. Norris, and P. S. Ramey, *J. Am. Chem. Soc.*, **76**, 4558 (1954).

(39) R. N. Jones et al., *NRC Bull.*, No. 11, 12, and 13 (1968, 1969).

(33) E. Kloster-Jensen, *Acta Chem. Scand.*, **17**, 1859 (1963).

(34) H. Biltz and E. Küppers, *Ber.*, **37**, 4412 (1904).

(35) M. F. Shostakovskii, N. V. Komarov, and O. G. Yarosh, *Izv. Akad. Nauk SSSR, Ser. Khim.*, **4**, 908 (1968).

## The Role of Collision Complexes in the Reaction of Silyl Ions with Ethylene<sup>1</sup>

R. N. Abernathy and F. W. Lampe\*

Contribution from the Department of Chemistry, The Pennsylvania State University, University Park, Pennsylvania 16802. Received July 2, 1980

**Abstract:** The reaction of  $\text{SiH}_3^+$  ions with  $\text{C}_2\text{H}_4$  was studied at laboratory energies in the range of 2.5–4.7 eV and pressures of 0.25–5 mtorr, using a tandem mass spectrometric technique. In agreement with earlier work, it was found that long-lived collision complexes play a major role in the reaction. However, at the reactant-ion energies and target gas pressures studied, the traditional mechanism of collisional stabilization plays no role; the route to detectable (i.e., long-lived) complexes involves a moderation of the kinetic energy of the reactant ions via complex formation and dissociation back to reactants.

Persistent collision complexes have long been cited as intermediates in chemical reactions and in recent years have received considerable emphasis in studies of ion-molecule reactions. Indirect evidence from beam studies in the form of velocity and angular distributions of product ion intensities<sup>2–11</sup> is strongly

supportive of the existence of long-lived collision complexes. However, by far the strongest demonstration for the existence of a persistent collision complex is the actual registration at the detector of the 1:1 adduct of reactants under conditions such that

(1) U.S. Department of Energy Document No. DE-AS02-76ER03416-15.

(2) Herman, Z.; Wolfgang, R. "Ion-Molecule Reactions"; Franklin, J. L., Ed.; Plenum Press: New York, 1972; Chapter 12.

(3) Herman, Z.; Lee, A.; Wolfgang, R. *J. Chem. Phys.* **1969**, *51*, 452.

(4) Ding, A.; Henglein, A.; Lacmann, K. *Z. Naturforsch., A* **1968**, *23A*, 779.

(5) Ding, A. *Z. Naturforsch., A* **1969**, *24A*, 856.

(6) Doverspike, L. D.; Champion, R. C. *J. Chem. Phys.* **1967**, *46*, 4718.

(7) Matus, L.; Opauszhy, I.; Hyatt, D.; Mason, A. J.; Birkinshaw, K.; Henchman, M. J. *Discuss. Faraday Soc.* **1967**, *44*, 146.

(8) Durup, J.; Durup, M. *J. Chem. Phys.* **1967**, *64*, 386.

(9) Chiang, M. H.; Gislason, E. A.; Mahan, B. H.; Tsao, C. W.; Warner, A. S. *J. Phys. Chem.* **1971**, *75*, 1426.

(10) Eisele, G.; Henglein, A. *Int. J. Radiat. Phys. Chem.* **1975**, *7*, 293.

(11) Eisele, G.; Henglein, A.; Botschwina, P.; Meyer, W. *Ber. Bunsenges. Phys. Chem.* **1974**, *78*, 1090.

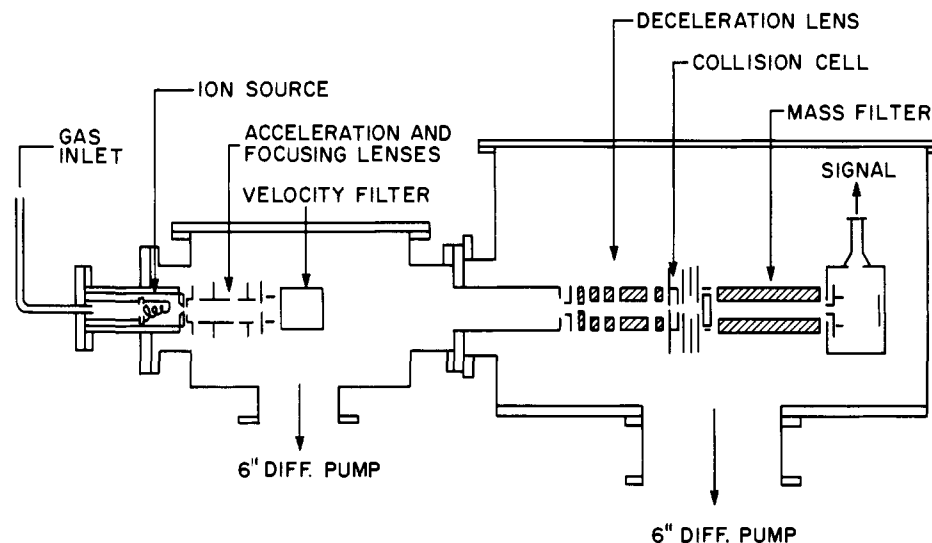

Figure 1. Schematic diagram of the instrument.

it has not been stabilized by a collision.

Several years ago, Allen and Lampe<sup>12,13</sup> reported the direct detection of unstabilized collision complexes in the reactions of low-energy silicon-containing ions with ethylene and benzene. In this work, the reaction of  $\text{SiH}_3^+$  ions with  $\text{C}_2\text{H}_4$  was studied at relative kinetic energies in the range of 0.47–2.4 eV, but only below 1 eV were unstabilized collision complexes sufficiently long-lived to survive the transit time of the apparatus. While the mean lifetime of the collision complexes was observed to decrease with increasing collision energy, the large kinetic energy spread of the  $\text{SiH}_3^+$  beam ( $\geq 1$  eV) and the limited energy range of detectability precluded the establishment of a meaningful relationship between the internal energy of the collision complexes, the mean lifetimes, and the rate coefficients for collisional stabilization. An additional aspect of this work that warrants confirmation is the surprisingly large value that was found for the rate coefficient for collisional stabilization.

A new ion-beam apparatus, constructed in our laboratory, produces reactant ion beams with kinetic energy spreads that are typically of the order of 0.3 eV.<sup>14,15</sup> With the much improved energy resolution provided, we have reinvestigated the reaction of  $\text{SiH}_3^+$  ions with  $\text{C}_2\text{H}_4$ .

### Experimental Section

The experiments were carried out in an ion-beam-scattering gas apparatus, a schematic diagram of which is shown in Figure 1.

The ion-gun section (consisting of ion source, acceleration and focusing lens, Wien filter, and deceleration lens) was obtained from Colutron Corp.<sup>16</sup> The ion source was modified by replacement of the boron nitride block with a quartz liner for the containment of the electric discharge. Following use with reactive gases such as monosilane, the quartz liner can be cleaned by sandblasting and so reused several times. We found that the use of quartz eliminated memory effects and the presence of  $\text{N}_2^+$  and  $\text{N}_2\text{H}^+$  ions, which we have observed when reactive gases containing hydrogen are ionized in the boron nitride source. The Wien velocity filter<sup>17-19</sup> was modified to allow water cooling and therefore operation at higher magnetic fields than would be the case otherwise. Since the ions extracted from the source are accelerated to the same energy (200 eV), the Wien filter acts also as a mass filter, permitting isolation of ions produced in the source for reaction with a gas in the collision chamber. At 200-eV acceleration energy, a deflection field of

37 V/cm, and a drift distance of 50 cm, we have found baseline resolution for mass separation by the Wien filter up to  $m/q = 60$  amu. In the experiments reported here,  $\text{SiH}_3^+$  ions, formed from monosilane in the source, are selected by the filter and slowed down by the deceleration lens prior to their entrance into the collision cell containing ethylene at pressures in the range of  $(0.2\text{--}5) \times 10^{-3}$  torr. The actual energies of the ions entering the reaction cell were calibrated in terms of the nominal energies by comparison of measured thresholds with those calculated<sup>20</sup> for several known endoergic reactions of rare-gas ions, namely, eq 1–3.

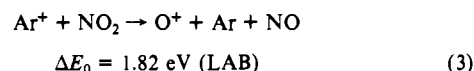
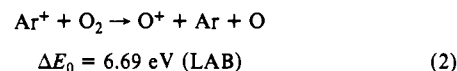
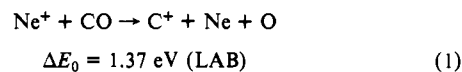

The lowest actual ion energy at which meaningful measurements could be made was 2.5 eV (LAB). The current of  $\text{SiH}_3^+$  ions entering the reaction cell was typically  $3 \times 10^{-11}$  A at an energy of 3 eV (LAB).

The quadrupole mass filter, used to separate the ions emerging from the collision cell, was constructed with stainless-steel rods that are 6 in. long and  $1/4$  in. in diameter. The quadrupole power supply, radio frequency power source, and high-Q-head were obtained from Extranuclear Laboratories, Inc.

The current of ions transmitted by the quadrupole mass filter was measured by a Channeltron continuous-dynode electron multiplier. The multiplier is mounted off the axis of the instrument, in order to avoid detection of fast neutral species.

Monosilane was purchased from Union Carbide Co.—Linde Division, monosilane- $d_4$  and ethylene- $d_4$  from Merck and Co., and ethylene, argon, and neon from the Matheson Co. All gases were subjected to freeze-pump-thaw cycles prior to use and were checked by mass spectrometry for satisfactory purity.

### Results and Discussion

(1) **Nature of the Reaction.** When a beam of  $\text{SiH}_3^+$  ions, with laboratory energy in the range of 2.5–4.7 eV, impinges on  $\text{C}_2\text{H}_4$  at 1-mtorr pressure and ambient temperature, the product ions observed are  $\text{SiC}_2\text{H}_7^+$  ( $m/q = 59$  amu),  $\text{SiC}_2\text{H}_5^+$  ( $m/q = 57$  amu),  $\text{SiC}_2\text{H}_3^+$  ( $m/q = 55$  amu), and  $\text{SiCH}_3^+$  ( $m/q = 43$  amu). The observed mass spectra of products from the reaction of monoisotopic  $^{28}\text{SiH}_3^+$  ions, having a laboratory kinetic energy of 2.6 eV, with  $\text{C}_2\text{H}_4$  at several pressures are shown in Figure 2. In this figure the ionic abundances are given as fractions of the total observed product ion intensity. In agreement with Allen and Lampe,<sup>12</sup> the effect of increasing the  $\text{C}_2\text{H}_4$  pressure is to increase

(12) Allen, W. N.; Lampe, F. W. *J. Am. Chem. Soc.* **1977**, *99*, 6816.

(13) Allen, W. N.; Lampe, F. W. *J. Chem. Phys.* **1976**, *65*, 3378.

(14) Goodloe, G. W.; Austin, E. R.; Lampe, F. W. *J. Am. Chem. Soc.* **1979**, *101*, 3472.

(15) Herbst, E.; Champion, R. L.; Doverspike, L. D. *J. Chem. Phys.* **1975**, *63*, 3677.

(16) Menzinger, M.; Wählin, L. *Rev. Sci. Instrum.* **1969**, *40*, 102.

(17) Wien, W. *Ann. Phys. Chem.* **1898**, *65*, 440.

(18) Wählin, L. *Nucl. Instrum. Methods* **1965**, *38*, 133.

(19) Menzinger, M.; Wolfgang, R. *J. Chem. Phys.* **1969**, *50*, 2991.

(20) Rosenstock, H. M.; Draxl, K.; Steiner, B. W.; Herron, J. T. *J. Phys. Chem. Ref. Data* **1977**, *6*, Suppl. No. 1.

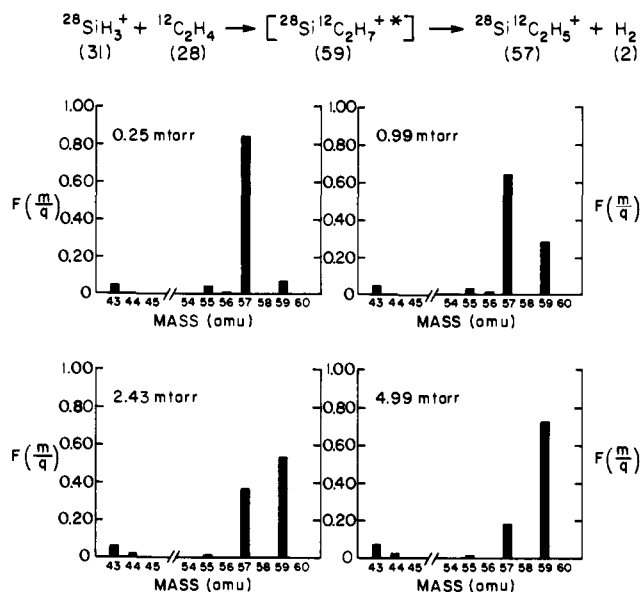

**Figure 2.** The dependence on pressure of ethylene of the observed fractional abundances of the ionic products for 2.6-eV (LAB)  $\text{SiH}_3^+$  ions.

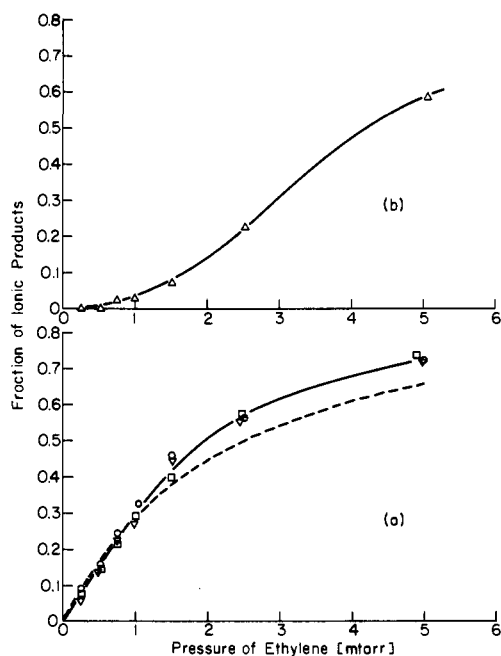

**Figure 3.** The effect of pressure of  $\text{C}_2\text{H}_4$  on the abundance of  $m/q = 59$  amu: (a) 2.5 (○), 2.6 (▽) and 2.8 (◻) eV (LAB)  $\text{SiH}_3^+$ ; (b) 4.7 (Δ) eV (LAB)  $\text{SiH}_3^+$ . The broken line indicates the calculated dependence of  $F_{59}$  upon pressure of ethylene for 2.6 eV (LAB).

markedly the relative abundance of  $\text{SiC}_2\text{H}_7^+$ , so that at 5 mtorr this ion accounts for over 70% of the observed ionic products. At the same time, the relative intensities of  $\text{SiC}_2\text{H}_5^+$  and  $\text{SiC}_2\text{H}_3^+$  undergo a parallel decrease, while the relative intensity of  $\text{SiCH}_3^+$  is virtually independent of  $\text{C}_2\text{H}_4$  pressure. These results confirm the conclusion<sup>12</sup> that  $\text{SiC}_2\text{H}_5^+$  and  $\text{SiC}_2\text{H}_3^+$  arise from a unimolecular decomposition of the collision complex,  $\text{SiC}_2\text{H}_7^{+\ast}$ , that is in competition with a pressure-dependent stabilization that yields  $\text{SiC}_2\text{H}_7^+$ . The ion  $\text{SiCH}_3^+$  is presumably not formed via the  $\text{SiC}_2\text{H}_7^{+\ast}$  collision complex but rather by a direct process that is independent of pressure.

The detailed effect of  $\text{C}_2\text{H}_4$  pressure on the relative abundance of  $\text{SiC}_2\text{H}_7^+$  is shown in Figure 3a for  $\text{SiH}_3^+$  ions of 2.5, 2.6, and 2.8 eV. Here it may be seen that in the limit of zero pressure the fraction of  $\text{SiC}_2\text{H}_7^+$  detected is zero. This means that for reactant ions of this energy the collision complex does not have a sufficient lifetime, relative to decomposition, to survive the transit time to the detector. In this regard, Allen and Lampe<sup>12</sup> observed

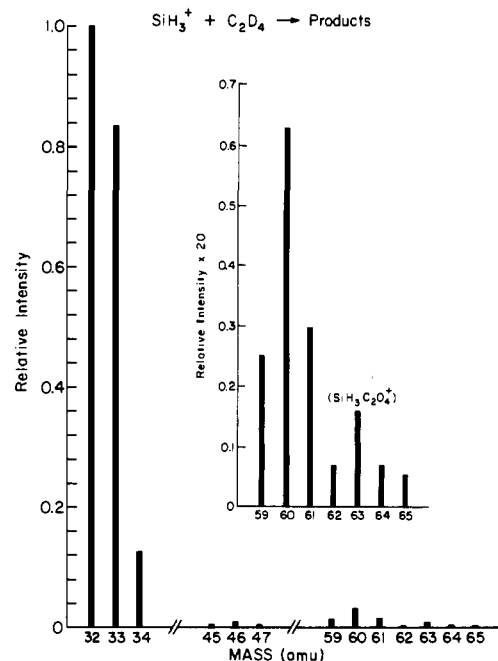

**Figure 4.** The relative amount of forward (i.e.,  $m/q = 59$  through  $m/q = 65$ ) and backward (i.e.,  $m/q = 31, 32, 33,$  and  $34$ ) unimolecular decomposition for 2.6-eV (LAB)  $\text{SiH}_3^+$ .  $P(\text{C}_2\text{D}_4) = 0.25$  mtorr.

finite fractions of  $m/q = 59$  in the limit of zero pressure, i.e., sufficiently long-lived collision complexes,  $\text{SiC}_2\text{H}_7^{+\ast}$ , but only for kinetic energies of  $\text{SiH}_3^+$  reactant less than 2 eV (LAB), an energy below what is obtainable with the present apparatus.

To attempt to ascertain the extent of the decomposition of  $\text{SiC}_2\text{H}_7^{+\ast}$  back to the reactants  $\text{SiH}_3^+$  and  $\text{C}_2\text{H}_4$ , we examined the reaction of  $\text{SiH}_3^+$  with  $\text{C}_2\text{D}_4$ ; obviously the reformation of  $\text{SiH}_3^+$  in the all-protium system cannot be detected in the presence of the much more intense primary  $\text{SiH}_3^+$  ion beam. The spectrum of product ions obtained when 2.6-eV  $\text{SiH}_3^+$  ions are injected into  $\text{C}_2\text{D}_4$  at a pressure of 0.25 mtorr is shown in Figure 4. It may be seen in this figure that ionic products are observed at  $m/q = 32, 33$  and  $34$  which must be attributed to the ions  $\text{SiH}_2\text{D}^+$ ,  $\text{SiHD}_2^+$ , and  $\text{SiD}_3^+$ , respectively. The intensity of any  $\text{SiH}_3^+$  formed by dissociation of the collision complex cannot be determined due to the very high intensity of unreacted  $\text{SiH}_3^+$  ions. Figure 4 also permits a comparison to be made of the intensities of these deuterated silyl ions with the intensities of the products of the forward reaction, namely, the ions in the  $m/q$  range of 59–63 amu. The comparison indicates that the predominant reaction of  $\text{SiC}_2\text{H}_7^{+\ast}$  (i.e., >90%) at this pressure is dissociation back to reactants. Furthermore, it may be noted in Figure 4 that, in addition to the complex  $\text{SiC}_2\text{H}_3\text{D}_4^+$  at  $m/q = 63$  amu, significant intensities of ions at  $m/q = 64$  and  $65$  amu are detected. These latter ions must be  $\text{SiC}_2\text{H}_2\text{D}_5^+$  and  $\text{SiC}_2\text{HD}_6^+$ , respectively, and they most probably arise from addition of  $\text{SiH}_2\text{D}^+$  and  $\text{SiHD}_2^+$  to  $\text{C}_2\text{D}_4$ , a conclusion that is strengthened by the fact that the intensities of  $m/q = 64$  amu ( $\text{SiH}_2\text{DC}_2\text{D}_4^+$ ) and  $m/q = 65$  amu ( $\text{SiHD}_2\text{C}_2\text{D}_4^+$ ) are in the same ratio as those at  $m/q = 32$  amu ( $\text{SiH}_2\text{D}^+$ ) and  $m/q = 33$  amu ( $\text{SiHD}_2^+$ ). Since a further collision of the complexes  $\text{SiC}_2\text{H}_2\text{D}_5^+$  and  $\text{SiC}_2\text{HD}_6^+$  at this low pressure is extremely unlikely, these collision complexes must be stable, i.e., have lifetimes sufficiently long to survive the transit time of the apparatus.

The effect of  $\text{D}_2$  and  $(\text{CD}_3)_4\text{Si}$  as foreign third bodies on the yield of  $\text{SiC}_2\text{H}_7^+$  was investigated by varying the partial pressure of the foreign bath molecules at constant pressure of  $\text{C}_2\text{H}_4$ . The results of such experiments are shown in Figure 5 in which the fractional yield of  $\text{SiC}_2\text{H}_7^+$  is plotted as a function of partial pressure of bath molecule. Rather surprisingly it is seen here that  $\text{D}_2$  is a more effective third body than  $(\text{CD}_3)_4\text{Si}$ . This will be discussed in a later section.

(2) **Kinetics and Mechanism.** The data shown in Figures 3 and

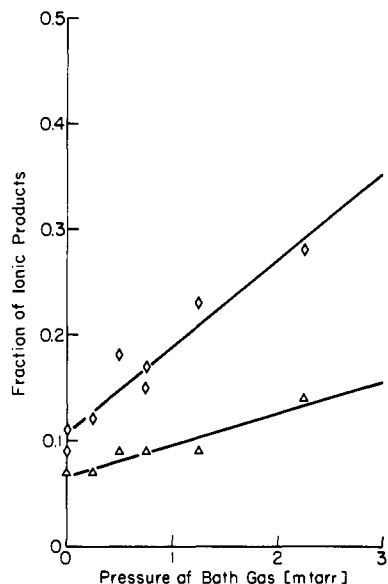

**Figure 5.** Enhancement of abundance of  $\text{SiC}_2\text{H}_7^+$  by foreign bath gases:  $\text{D}_2$  ( $\diamond$ );  $(\text{CD}_3)_4\text{Si}$  ( $\triangle$ ).  $P(\text{C}_2\text{H}_4) = 0.25$  mtorr.

4 indicate that the predominant part of the reaction proceeds via a collision complex,  $\text{SiC}_2\text{H}_7^{+*}$ , that is formed by the initial interaction between an  $\text{SiH}_3^+$  ion in the beam and a  $\text{C}_2\text{H}_4$  molecule in the reaction cell. The traditional mechanism of chemical kinetics that is usually invoked to account for the effect of pressure on the abundances of products, in this case  $\text{SiC}_2\text{H}_7^+$ ,  $\text{SiC}_2\text{H}_5^+$ , and  $\text{SiC}_2\text{H}_3^+$ , is that of collisional deactivation. In this mechanism the collision complex,  $\text{SiC}_2\text{H}_7^{+*}$ , is assumed<sup>12</sup> to be stabilized to  $\text{SiC}_2\text{H}_7^+$  as a result of the internal energy transfer that occurs upon collision with  $\text{C}_2\text{H}_4$ ; such stabilization produces  $\text{SiC}_2\text{H}_7^+$  at the expense of the decomposition products  $\text{SiC}_2\text{H}_5^+$  and  $\text{SiC}_2\text{H}_3^+$ .

The difficulty with application of this traditional mechanism to the results in Figure 3a is that it requires the assignment of absurdly high values to the rate constant for the collisional stabilization process, namely, values up to 1 order of magnitude larger than the Langevin rate constant for orbiting collisions. The traditional mechanism of collisional stabilization of  $\text{SiC}_2\text{H}_7^{+*}$  by  $\text{C}_2\text{H}_4$ <sup>12</sup> is therefore an unlikely explanation of the observed increase in the relative intensity of  $\text{SiC}_2\text{H}_7^+$  with increasing pressure of  $\text{C}_2\text{H}_4$  (cf. Figure 3).

We suggest that an alternative mechanism, namely, *reactant-ion moderation*, is responsible for the experimental facts displayed in Figures 3 and 4. In this mechanism the original collision complex formation and very rapid dissociation back to reactants (which is the predominant reaction) reduces the kinetic energy of the reactant ions significantly. These moderated  $\text{SiH}_3^+$  ions can then form long-lived collision complexes on a subsequent collision with  $\text{C}_2\text{H}_4$ . For example, with the assumption that  $\text{C}_2\text{H}_4$  molecules have zero velocity, simple conservation of momentum shows that a beam of monoenergetic  $\text{SiH}_3^+$  ions of 2.6-eV kinetic energy will form collision complexes having a kinetic energy of 1.4 eV. The dissociation of this complex back to reactants then yields  $\text{SiH}_3^+$  ions having a distribution of kinetic energies centered about 0.72 eV. Since Allen and Lampe<sup>12</sup> showed that  $\text{SiH}_3^+$  at kinetic energies below 2 eV in the laboratory system yields stable or long-lived collision complexes, many of the so-moderated  $\text{SiH}_3^+$  ion will, on subsequent collision with  $\text{C}_2\text{H}_4$ , produce the observed  $\text{SiC}_2\text{H}_7^+$  ions. The mechanism we propose that embodies these ideas and accounts for the experimental facts is shown in Scheme I. In this mechanism  $E_0$  represents the kinetic energy of unmoderated reactant ions and  $E_1$ , the kinetic energy of reactant ions moderated once by complex formation and dissociation, etc. For simplicity we have omitted the formation of the minor product  $\text{SiC}_2\text{H}_3^+$ .

### Scheme I

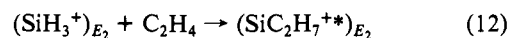
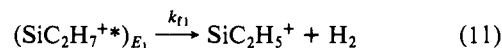
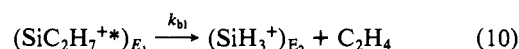
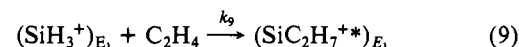
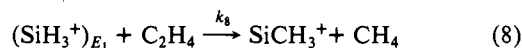
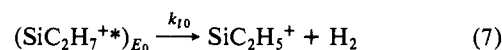
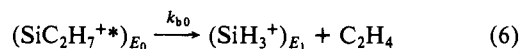
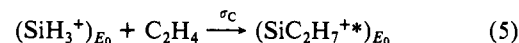
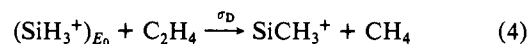

At the lowest energies studied, 2.5–2.8 eV, the linear increase in fractional abundance of observed  $\text{SiC}_2\text{H}_7^+$  ( $m/q = 59$ ) with  $\text{C}_2\text{H}_4$  pressure (cf. Figure 3a) indicates that single-collision moderation of the  $\text{SiH}_3^+$  ions is effective. In terms of the above mechanism this means that (10) and (11) do not occur because  $k_{b1}$  and  $k_{f1}$  are zero, i.e.,  $(\text{SiC}_2\text{H}_7^{+*})_{E_1}$  is long-lived relative to the detection time of the apparatus. Also, (12) does not occur because  $(\text{SiH}_3^+)_{E_2}$  is not formed. At the highest energy studied, namely, 4.7 eV, the quadratic increase in fractional abundance of the observed  $\text{SiC}_2\text{H}_7^+$  ( $m/q = 59$ ) with  $\text{C}_2\text{H}_4$  pressure (cf. Figure 3b) indicates that two collisions are required for moderation of the  $\text{SiH}_3^+$  ions. In terms of the mechanism this means that at this energy  $(\text{SiC}_2\text{H}_7^{+*})_{E_1}$  is not stable but rather undergoes the dissociation (10) and (11); on the other hand  $(\text{SiC}_2\text{H}_7^{+*})_{E_2}$  is long-lived with respect to the transit time of the apparatus and is detected.

Qualitatively, the pressure dependence of the  $\text{SiC}_2\text{H}_7^+$  yield is the same for the above moderation mechanism as for the collisional stabilization mechanism in which the complex  $\text{SiC}_2\text{H}_7^{+*}$  would have energy removed by collision with  $\text{C}_2\text{H}_4$ . However, the initial slope of the low-energy curve in Figure 3 is such that the rate constant required for the collisional energy-transfer reaction is unacceptably large. As will be shown the moderation mechanism above does not suffer from this difficulty.

A further confirmation of the above moderation mechanism, as contrasted to a mechanism involving collisional stabilization of  $\text{SiC}_2\text{H}_7^{+*}$ , is evident from the effects of foreign bath gases on the reaction. As shown in Figure 5, for constant partial pressures of  $\text{C}_2\text{H}_4$ ,  $\text{D}_2$  is nearly three times more effective than  $(\text{CD}_3)_4\text{Si}$  in increasing the yield of  $\text{SiC}_2\text{H}_7^+$ . The transfer of vibrational energy to the bath gas, which is the major process involved in the collisional stabilization mechanism, must be expected to occur much more readily with  $(\text{CD}_3)_4\text{Si}$  than with  $\text{D}_2$  because of the much greater number of vibrational modes in the former. The fact that just the reverse is true strongly suggests that the traditional collisional stabilization mechanism is not operative in this system under our conditions. The very low efficiency of  $(\text{CD}_3)_4\text{Si}$  as a moderator of the energy of  $\text{SiH}_3^+$  reactant ions is explained by the fact that an extremely efficient reaction channel, namely, (13), exists which is in competition with collision complex for-

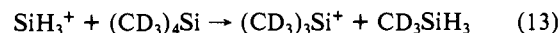

mation and, thus, with reactant ion moderation. The transfer of  $\text{CD}_3^-$  ions from alkylsilanes, i.e., (13), appears to be a direct process that does not proceed via long-lived collision complexes.<sup>14,21</sup> No such competitive channel to complex formation exists in the case of  $\text{SiH}_3^+ - \text{D}_2$  collisions.<sup>22</sup>

(21) Goodloe, G. W.; Lampe, F. W. *J. Am. Chem. Soc.* **1979**, *101*, 6028.

(22) Allen, W. N.; Cheng, T. M. H.; Lampe, F. W. *J. Chem. Phys.* **1977**, *66*, 3371.

Describing the various product ion abundances as fractions of the total product ion intensity, the pertinent rate equations that describe the time dependence of the collision complexes subsequent to the formation of  $(\text{SiC}_2\text{H}_7^{+*})_{E_0}$ , i.e., subsequent to the occurrence of R(5), and in the low-energy regions where single-collision moderation (cf. Figure 3a) is operative, are eq I–III. In (I)–(III),

$$-\frac{dF[(\text{SiC}_2\text{H}_7^{+*})_{E_0}]}{dt} = \tau_0^{-1}F[(\text{SiC}_2\text{H}_7^{+*})_{E_0}] \quad (\text{I})$$

$$\frac{dF[(\text{SiH}_3^+)_{E_1}]}{dt} + k_9 n F[(\text{SiH}_3^+)_{E_1}] = k_{b0} F[(\text{SiC}_2\text{H}_7^{+*})_{E_0}] \quad (\text{II})$$

$$\frac{dF[(\text{SiC}_2\text{H}_7^{+*})_{E_1}]}{dt} = k_9 n F[(\text{SiH}_3^+)_{E_1}] \quad (\text{III})$$

$\tau_0$  is the mean lifetime of  $(\text{SiC}_2\text{H}_7^{+*})_{E_0}$  with respect to decomposition, i.e.,  $\tau_0 = (k_{b0} + k_{r0})^{-1}$ ,  $n$  is the number density of  $\text{C}_2\text{H}_4$  molecules in the reaction chamber, and  $F[X^+]$  is the ion fraction of  $X^+$  as described above. Similar equations may be written for the product ions  $\text{SiC}_2\text{H}_5^+$  and  $\text{SiCH}_3^+$ .

Assuming that  $n = n$  inside the collision chamber and that  $n = 0$  outside the chamber in the drift region, we may integrate (I)–(III) over the two regions to obtain explicit expressions for the detected ion fractions of interest. The result is shown in eq IV–VI, in which  $t_c$  is the reaction time available in the collision

$$F[(\text{SiC}_2\text{H}_7^{+*})_{E_0}] = \xi_0 e^{-t/\tau_0} \quad (\text{IV})$$

$$F[(\text{SiC}_2\text{H}_7^{+*})_{E_1}] = \xi_0 \xi_1 k_{b0} \tau_0 \left( 1 + \frac{e^{-k_9 n t_c} - k_9 \tau_0 n e^{-t_c/\tau_0}}{k_9 \tau_0 n - 1} \right) \quad (\text{V})$$

$$F[(\text{SiH}_3^+)_{E_1}] = \xi_0 k_{b0} \tau_0 e^{-t_c/\tau_0} \left( \frac{1 - e^{(\tau_0^{-1} - k_9 n) t_c}}{k_9 \tau_0 n - 1} + 1 - e^{-t_d/\tau_0} \right) \quad (\text{VI})$$

chamber,  $t_d$  is the time available in the drift region, and  $t_d + t_c = t$ . The quantities  $\xi_0$  and  $\xi_1$  are defined by eq VII and VIII, respectively.

$$\xi_0 = \sigma_c / (\sigma_c + \sigma_D) \quad (\text{VII})$$

$$\xi_1 = k_9 / (k_8 + k_9) \quad (\text{VIII})$$

The experimental ion-fractions, plotted as ordinates in Figures 2, 3, and 5, were calculated from the intensities of the observed product ions which do not include the unobservable  $(\text{SiH}_3^+)_{E_1}$ . The relationship between the experimentally observed ion fraction of  $m/q = 59$  amu,  $F'_{59}$  shown in Figure 3, and the ion fractions given in (IV)–(VI) is given by (IX). Substitution of (IV)–(VI) into (IX) yields a very cumbersome expression, the zero-pressure limit

$$F'_{59} = \frac{F[(\text{SiC}_2\text{H}_7^{+*})_{E_0}] + F[(\text{SiC}_2\text{H}_7^{+*})_{E_1}]}{1 - F[(\text{SiH}_3^+)_{E_1}]} \quad (\text{IX})$$

of which is (X). According to (X), the fact that within exper-

$$\lim_{n \rightarrow 0} F'_{59} = \frac{\xi_0 e^{-t/\tau_0}}{1 - k_{b0} \tau_0 \xi_0 (1 - e^{-t/\tau_0})} \quad (\text{X})$$

imental error the limit is found to be zero (cf. Figure 3) means that  $\tau_0 \ll t$ . The predicted expression for  $F'_{59}$  may be simplified by utilization of this fact along with two other reasonable approximations: (1) the absence of collisional stabilization of  $(\text{SiC}_2\text{H}_7^{+*})_{E_0}$ , which can occur only in the reaction chamber, indicates that  $\tau_0 \ll t_c$ ; and (2) making the reasonable assumption that  $k_9$  is no greater than the Langevin orbiting rate constant, it may be shown that, in our pressure range,  $\tau_0^{-1} \gg k_9 n$ . Combining these inequalities with (IV)–(VI) and (IX) yields the approximate expression for  $F'_{59}$  shown in (XI). The zero-pressure limit for

$$F'_{59} = \frac{k_{b0} \xi_0 \xi_1 \tau_0 (1 - e^{-k_9 n t_c})}{1 - k_{b0} \tau_0 \xi_0 e^{-k_9 n t_c}} \quad (\text{XI})$$

$F'_{59}$  is easily seen from (XI) to be zero, in agreement with Figure

3. Other pertinent limiting forms of  $F'_{59}$ , the numerical values of which are obtained from the data in Figure 3a, are easily obtained from (XI) and are

$$\lim_{n \rightarrow \infty} F'_{59} = \xi_0 \xi_1 k_{b0} \tau_0 = 0.88 \quad (\text{XII})$$

$$\lim_{n \rightarrow 0} \left( \frac{dF'_{59}}{dn} \right) = \frac{\xi_0 \xi_1 k_{b0} \tau_0 k_9 t_c}{1 - \xi_0 k_{b0} \tau_0} = 1.24 \times 10^{-14} \text{ cm}^3/\text{molecule} \quad (\text{XIII})$$

A test of the validity of the reactant ion moderation model may be made by determination of the value of  $k_9$  from (XII) and (XIII) and the experimental data. The quantity  $k_{b0} \tau_0 (= k_{b0}/k_{b0} + k_{r0})$  is the fraction of total reaction of the collision complex  $(\text{SiC}_2\text{H}_7^{+*})_{E_0}$  that is in the backward direction to reactants. The experiments in the  $\text{SiH}_3^+ - \text{C}_2\text{D}_4$  system (cf. Figure 4) indicate that the value of this fraction is at least 0.96 (the value obtained if the complex  $(\text{SiH}_3\text{C}_2\text{D}_4^+)$  reacts back to reactants with complete scrambling of H and D) but is probably closer to 0.98 which is obtained by assuming that  $i_{31}/i_{32} = i_{63}/i_{64}$  (cf. Figure 4). In any event, the maximum value of  $k_{b0} \tau_0$  is unity so that negligible error is involved in using the probable value of 0.98. Assuming that  $\xi_0 \xi_1 \approx \xi_0^2$ , we find from (XII) that  $\xi_0 \approx 0.95$  and substitution into (XIII) yields the result

$$k_9 t_c = 9.7 \times 10^{-16} \text{ cm}^3/\text{particle} \quad (\text{XIV})$$

The average reaction time in the collision cell ( $t_c$ ) was calculated in the following manner. First, the average distances traveled to the first collision, to the second collision, and to the third collision were calculated by using Langevin cross sections. Assuming conservation of linear momentum and employing Newton diagrams, we calculated the average velocities after each of the collisions (taking into account the acceptance angle of the detection system, which is a function of where in the collision cell the encounter occurs). Therefore, having the distances traveled between collisions and the average velocities after each of the collisions, it is a straightforward matter to calculate the times elapsed between each of the encounters. For each species the reaction time is taken to be the total time elapsed from initial collision of  $(\text{SiH}_3^+)_{E_0}$  with  $\text{C}_2\text{H}_4$  to the exit of that particular species from the collision cell. The average reaction time is merely the sum of the reaction times for each of the species (weighted by the probability of each species).

For  $(\text{SiH}_3^+)_{E_0}$  ions of 2.64 eV, the energy pertinent to (XIV) and Figure 3a, we find in this manner that  $t_c = 1.3 \times 10^{-6}$  s. Combining with (XIV) yields the value

$$k_9 = 7.5 \times 10^{-10} \text{ cm}^3/(\text{particle s}) \quad (\text{XV})$$

which is to be compared to the Langevin value of  $k_L = 1.26 \times 10^{-9} \text{ cm}^3/(\text{particle s})$ . This agreement attests to the general validity of our suggested mechanism of reactant-ion moderation via collision complex formation and dissociation. The same data (Figure 3a) treated by the traditional mechanism of collisional stabilization of energy-rich complexes requires a rate constant for stabilization that is at least 1 order of magnitude larger than  $k_L$ . This fact, coupled with the effect of foreign gases (cf. Figure 5), definitely rules out the collisional stabilization mechanism as being operative under the conditions of our experiment.

Of course, this is not to say that collisional stabilization does not exist. In the same system at lower initial energies, such as obtained in experiments of Allen and Lampe,<sup>12</sup>  $\tau_0$  becomes comparable to  $t_c$ , and under these conditions collisional stabilization becomes competitive with reactant-ion moderation. We believe the high value for the rate constant for stabilization found by Allen and Lampe<sup>12</sup> is due to the parallel occurrence of reactant-ion stabilization in their system which was not taken into account. Also, at much higher pressures than employed in this work, collisional stabilization can compete effectively with dissociation because  $k_{\text{stab}} n$  becomes comparable to  $\tau_0^{-1}$ .

Using the above value of  $k_9$  and a value of  $\tau_0$  calculated by RRKM theory,<sup>23</sup> we have used (IV)–(VI) and (IX) to compute  $F'_{59}$  as a function of the pressure of  $\text{C}_2\text{H}_4$ . The result is shown

as the dotted line in Figure 3a. Considering the uncertainties involved, particularly in  $t_c$  as the pressure is increased to above 1 micron, the agreement is quite good.

The rates of unimolecular decomposition of the complex both in the forward direction (eq 7) and the backward direction (eq 6) were calculated as a function of relative kinetic energy by the familiar Rice-Ramsberger-Kassel-Marcus theory.<sup>23</sup> This calculation, which was similar to that reported by Allen and Lampe,<sup>12</sup>

(23) Robinson, P. J.; Holbrook, K. A. "Unimolecular Reactions"; Wiley-Interscience: New York, 1972; Chapters 4 and 5.

indicates that with a Gaussian kinetic energy distribution of 0.3-eV width in the reactant ions, unstabilized collision complexes will be directly observable ( $\tau_0 \geq 10^{-6}$  s in our apparatus) only for laboratory energies of  $\text{SiH}_3^+$  below 1.4 eV (LAB). The fact that Allen and Lampe<sup>12</sup> observed unstabilized collision complexes at energies up to 2 eV (LAB) is to be attributed to the much wider kinetic energy spread in their  $\text{SiH}_3^+$  ion beam.

**Acknowledgment.** This research was supported by the U.S. Department of Energy under Contract DE-AS02-76ER03416. Thanks are also due to the Education Committee of the Gulf Oil Corp. for a grant that assisted in the construction of the apparatus.

## Infrared Spectrum of the Primary Ozonide of Ethylene in Solid Xenon

Christopher K. Kohlmeier and Lester Andrews\*

Contribution from the Chemistry Department, University of Virginia, Charlottesville, Virginia 22901. Received October 27, 1980

**Abstract:** Separate Xe/O<sub>3</sub> and Xe/C<sub>2</sub>H<sub>4</sub> mixtures were condensed on a CsI window at 50 K and then warmed to 80–100 K. Strong infrared absorptions due to the secondary ozonide and weaker bands at 409, 647, 727, 846, 927, 983, and 1214 cm<sup>-1</sup> replaced the ethylene and ozone absorptions. The latter new bands agree with earlier solid film and CO<sub>2</sub> matrix studies and are assigned to the primary ozonide. Isotopic substitution (<sup>16,18</sup>O<sub>3</sub>, <sup>18</sup>O<sub>3</sub>, CH<sub>2</sub>CD<sub>2</sub>, C<sub>2</sub>D<sub>4</sub>, <sup>13</sup>C<sub>2</sub>H<sub>4</sub>) provides a sound basis for vibrational assignments. A sextet splitting for the 647-cm<sup>-1</sup> antisymmetric O–O–O stretching mode in the 50% oxygen-18 enriched experiment confirms the primary ozonide structure and directly characterizes the weak O–O–O single bonds.

The mechanism of the reaction between ozone and olefins has attracted considerable attention.<sup>1-4</sup> Bailey's recent monograph<sup>1</sup> contains an excellent comprehensive review of this work, including evidence supporting the initial step as a 1,3-dipolar cycloaddition to form a five-membered ring 1. This mechanism was first

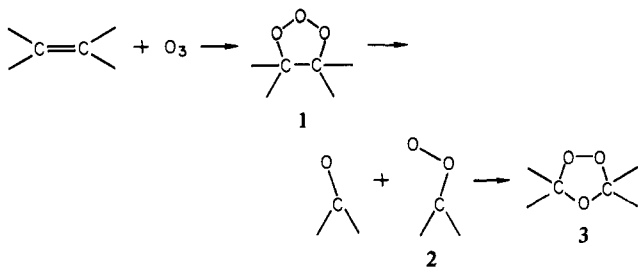

proposed by Criegee<sup>2</sup> in 1951. The 1,2,3-trioxolane, 1, is known as the primary ozonide (POZ) and the 1,2,4-trioxolane, 3, as the secondary ozonide (SOZ). The "Criegee intermediate", 2, was thought to exist as the zwitterion in solution,<sup>2</sup> but it is probably a diradical or dioxirane in the gas phase.<sup>5</sup> The symmetric nature of the POZ structure was demonstrated by Bailey et al.<sup>6</sup> from the low-temperature (-110 and -95 °C) NMR spectrum of the *trans*-1,2-di-*tert*-butylethylene POZ. Other NMR studies by Durham and Greenwood<sup>7</sup> have supported the symmetric structure of the POZ and established that the POZ is an intermediate in the ozonolysis reactions. This is consistent with the 1,2,3-trioxolane

structure but a  $\pi$ -complex cannot be eliminated. Such structures have been found with electron-rich systems, like aromatics,<sup>2</sup> and probably are formed at very low temperatures as precursors to the 1,2,3-trioxolane.<sup>8-11</sup>

Other authors have studied ozonolysis reactions by infrared spectroscopy. Hull et al.<sup>8</sup> deposited ozone and olefins (nine different compounds) separately onto a cold (-185 °C) window. After the window was warmed (-175 to 150 °C), two products were formed, presumably a  $\pi$ -complex and the 1,2,3-trioxolane (except C<sub>2</sub>H<sub>4</sub> formed only the 1,2,3-trioxolane). After the window was further warmed, the  $\pi$ -complex decomposed, probably to the initial reactants, but the POZ gave the SOZ and other products. The formations of the POZ's of *trans*-di-isopropylethylene and of 2,4,4-trimethylpent-1-ene in the liquid phase have been observed by Alcock and Mile.<sup>9,11</sup> Of particular interest, Nelander and Nord have studied the POZ of ozone and ethylene in CCl<sub>4</sub> and CO<sub>2</sub> matrices.<sup>12</sup>

Previous workers made POZ vibrational assignments based on an ozone model, which cannot be accurate for the 1,2,3-trioxolane structure. This paper characterizes the ethylene POZ fundamentals, and the POZ itself, using carbon-13, oxygen-18, and deuterium isotopic data for the first time. A xenon matrix affords the inertness needed for isotopic purity and the temperature range required for reaction. Similar isotopic data for the SOZ structures and attempts to isolate the Criegee intermediate will be discussed in a future paper.

### Experimental Section

**Apparatus.** The cryogenic refrigeration system and vacuum vessel have been previously described.<sup>13</sup> All spectra were recorded on a

(1) Bailey, P. S. "Ozonation in Organic Chemistry"; Academic Press: New York, 1978; Vol. I.

(2) Criegee, R. *Angew. Chem., Int. Ed. Engl.* **1975**, *14*, 745.

(3) Harding, L. B.; Goddard, W. A., III *J. Am. Chem. Soc.* **1978**, *100*, 7180.

(4) Lattimer, R. P.; Kuczkowski, R. L.; Gilles, C. W. *J. Am. Chem. Soc.* **1974**, *96*, 348. Fong, G. D.; Kuczkowski, R. L., *Ibid.*, to be published.

(5) Lovas, F. J.; Suenram, R. D. *Chem. Phys. Lett.* **1977**, *51*, 453. Suenram, R. D.; Lovas, F. J. *J. Am. Chem. Soc.* **1978**, *100*, 5117.

(6) Bailey, P. S.; Thompson, J. A.; Shoulders, B. A. *J. Am. Chem. Soc.* **1966**, *88*, 4098.

(7) Durham, L. J.; Greenwood, F. L. *J. Chem. Soc., Chem. Commun.* **1967**, 843; *J. Org. Chem.* **1968**, *33*, 1629.

(8) Hull, L. A.; Hisatsune, I. C.; Hecklen, J. *J. Am. Chem. Soc.* **1972**, *94*, 4856.

(9) Alcock, W. G.; Mile, B. *J. Chem. Soc., Chem. Commun.* **1976**, *5*; **1973**, 575.

(10) Nelander, B.; Nord, L. *J. Am. Chem. Soc.* **1979**, *101*, 3769.

(11) Mile, B.; Morris, Gareth W.; Alcock, W. G. *J. Chem. Soc. Perkin Trans. 2* **1979**, 1644.

(12) Nelander, B.; Nord, L. *Tetrahedron Lett.* **1977**, *32*, 2821.

(13) Andrews, L. *J. Chem. Phys.* **1968**, *48*, 972; **1971**, *54*, 4935.